

Beijing City Lab

Long Y, Han H, Tu Y, Zhu X, 2014, Evaluating the Effectiveness of Urban Growth Boundaries Using Human Mobility and Activity Records. Beijing City Lab. Working paper #56

Evaluating the Effectiveness of Urban Growth Boundaries Using Human Mobility and Activity Records

Ying Long, Beijing Institute of City Planning, longying1980@gmail.com

Haoying Han*, Zhejiang University, hanhaoying@zju.edu.cn

Yichun Tu, Department of City and Regional Planning, University of North Carolina at Chapel Hill, ytu@live.unc.edu

Xianfan Zhu, Zhejiang University, shuxianfan@gmail.com

* Corresponding author

Acknowledgments: We would like to acknowledge the financial support of the National Natural Science Foundation of China (No.51408039).

Abstract:

We proposed a methodology to evaluate the effectiveness of Beijing's Urban Growth Boundaries (UGBs) using human mobility and activity records (big data). The research applied data from location check-in, transit smart card, taxi trajectory, and residential travel survey. We developed four types of measures to evaluate the effectiveness of UGBs in confining human activities and travel flows, to examine the conformity of urban activities with the planned population, and to measure the activity connections between UGBs. With the large proportions of intra- and inter- boundary travel flows and an overwhelming majority of check-ins inside the UGBs, the research concluded that Beijing's UGBs were effective in containing human mobility and activity. However, the connections between UGBs, indicated by the spatial differentiation of the travel flows, were not consistent with the plan's intention and strategy. It indicated the potential underdevelopment of the public transit serving several new cities.

Keywords: Plan Implementation Evaluation, Big Data, Social Network, Transit Smartcard data, Beijing

Introduction

Evaluation of plan implementation is important because it reflects the extent to which a plan or a planning agency succeeds in predicting, guiding, and controlling future urban development. One common way to determine what a plan has accomplished is to measure the conformance degree between the actual outcomes or impacts and the proposed plans or policies. By doing so, planners can acquire insights about how the planning decision-making process operates and validate whether planning efforts do contribute to goal achievement (Alexandar & Faludi, 1989; Alexander, 2009; Talen, 1996b; Laurian, et al., 2004). Feedback from this evaluation helps establish a responsive and accountable plan-making and -implementation process, thus improving the overall quality of planning.

Since the early 1970s numerous studies have contributed to the theoretical and methodological understandings in the field of planning evaluation. A few studies have illustrated the evaluation approaches with one particular aspect of planning, including land development (Alterman & Hill, 1978; Berke, et al., 2006; Chapin, Deyle, & Baker, 2008), environmental planning (Brody & Highfield, 2005), public facilities and infrastructure (Laurian, et al., 2004; Talen, 1996a), and urban sprawl control (Nelson & Moore, 1993; Brody, Carrasco, & Highfield, 2006; Altes, 2006).

In this study we focused on assessing plan implementation in terms of the effectiveness of urban growth boundaries. As one of the most widely adopted urban containment policy tools, urban growth boundaries (UGBs) have been used to control the spread of urban areas, increase urban land use density, and protect open spaces (Pendall, Martin, & Fulton, 2002). The basic concept of implementing a UGB is to set a physical boundary separating urban and rural areas. Urban developments are not allowed outside the predefined boundary. Broadly speaking, the implementation of UGB also encompasses various regulatory techniques such as zoning and land development permits.

Evaluating plan implementation is particularly relevant in the case of UGB's implementation. Although an increasing number of cities in the U.S. and Europe have regarded UGBs as a key tool in controlling urban sprawl, there has been little systematic empirical studies of measuring the effectiveness of UGBs. This is partly because that plan implementation evaluation has rarely been given adequate attention in the planning profession. It has been an afterthought to the planning decision-making or implementation framing (Berke, et al., 2006; Talen, 1996a). Apart from the dearth in interest in planning evaluation, lack of data, robust evaluation theories and methodologies, as well as of the linkages between theory and practice are also among some of the major reasons for its limited applications in planning practices

(Talen, 1996a, 1996b; Brody, Highfield, & Thornton, 2006; Laurian, et al., 2004; Oliveira & Pinho, 2010).

In addition to these general issues, the development of UGBs implementation evaluation has also been constrained by the oversimplified evaluation dimension. To date, most of relevant studies are centered on assessing the physical outcomes, that is, the degree to which the actual urban extent and development layout conform to the proposed land use plans. For instances, a number of studies have utilized remote sensing images and geographic information system to track land coverage changes (Hasse, 2007; Hepinstall-Cymerman, Coe, & Hutyra, 2013). Among them, Han *et al.* (2009) have examined the effectiveness of the urban construction boundaries (UCB) in Beijing across two intervals, 1983-1993 and 1993-2005 and concluded that the UCBs failed to contain urban growth. Some studies have focused on analyzing the driving forces of the urban expansion (Boarnet, McLaughlin, & Carruthers, 2011; Brueckner & Fansler, 1983; Burchfield *et al.*, 2006; Long, Gu, & Han, 2012). Using quantitative techniques such as regression models, these studies have helped identify the effects of particular variables (e.g. planning and political elements, built environments, and socioeconomic attributes) on urban expansion or land development. Yet one of the major problems associated with these studies is that they simply equal urban expansion to the changes in land coverage or use. What has been ignored is the assessment of how human activities actually react to these boundaries set forth by urban containment policies. After all, the types of activities and the way people engage in these activities fundamentally are correlated with land use and development patterns. What are the relations between urban activities and UGBs? Do the UGBs really work on shaping and controlling urban development and activities? Unfortunately, previous studies have provided few clues or solutions to these questions.

In this study, we evaluated the effectiveness of UGBs from the perspective of human activities using location check-in from social network and smartcard data from public transit system. The increasing availability of urban big data, such as mobile traces and public transit records, has provided unprecedented opportunities for urban researchers and planners to better understand and manage urban systems. These data have enabled us to describe and analyze real-time human behaviors and movements in a more precise, reliable, and economic way. We also see the potential of applying these data in planning evaluation, particularly in countries where official statistics are less sufficient or reliable. Based on the analysis of the massive data on human activities, the study aims to (1) evaluate the effectiveness of UGBs in confining human activities, (2) examine whether the intensity of urban activities correlate to that of planned population across UGBs, and (3) measure the activity connections between UGBs.

This study selected Beijing City as a case to illustrate how the evaluation is developed. The methodologies adopted in this study also apply in cities in other countries. In section 2, we introduced the study context and the sources of data. In section 3, we elaborated the methodology and presumptions, as well as the evaluation results. In section 4, we discussed the findings in details. In section 5, we concluded by summarizing our findings, suggesting the strength and weakness of our study, and giving recommendations for potential subsequent studies in future.

Study Area and Data

Beijing's Recent Urban Planning

Beijing is the capital of China and one of the most populous cities in the world. The population at the end of 2013 was 21.15 million. The area of Beijing Metropolitan Area (BMA) is 16,410 square kilometers. According to land use dataset of Beijing Institute of City Planning, the total urban area as of 2012 was 1,675 square kilometers. The BMA currently comprises 16 administrative subdivisions, as illustrated in Figure 1.

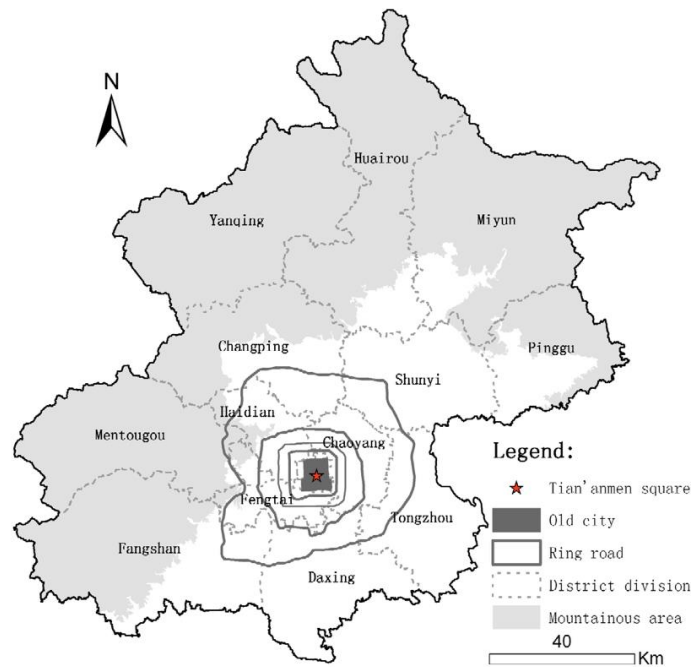

Fig.1. The Beijing Metropolitan Area

Since the latest adjustment of the Beijing administrative boundaries in 1958, five urban master plans have been drafted in 1958, 1973, 1982, 1992 and 2004 respectively. Each master plan includes an official land use map. Individual land parcels in the map were assigned according to a classification of either urban (residential, commercial, industrial, public green

land, and mixed-use land) or non-urban (farmland, forestland, and wetland) uses (Long, Gu, & Han, 2012). The map guided the future urban development, and actual land uses were expected to conform to the plan.

Since the beginning of the 1990s, the BMA has experienced an unprecedented increase in population growth and urban development. By the year 2003, Beijing's population and urban built-up area had already surpassed the capacity set forth in the 1992 -2010 Master Plan. To cope with new challenges in the future, the Beijing Municipal Commission of Urban Planning updated the city's master plan for a 2020 planning horizon. Approved in 2005, the revised plan was sought to outline general principles and create new guidelines for Beijing's long-term economic, social, and physical development (Ding , Song, & Knaap, 2005).

In this new plan, the projected population of Beijing is 18 million in 2020, with a total area of 16,410 square kilometers. From a spatial perspective, the plan promotes a "two-axis, two-belt, and multi-sub-centers" urban development pattern. A total area of 1,650 square kilometers of planned urban built-up area is allocated to the central city and eleven new towns. Urban development were planned to occur within the planned urban construction areas. The boundaries of these areas can be regarded as the Chinese UGBs which functioned in a similar way as the UGBs in the U.S. The issuance of land use permits outside these boundaries was generally forbidden in order to curb urban expansion and protect open spaces. Overall, four types of UGBs are identified, including those in the central city, new cities, towns, and other small isolated areas.

Date Sources

Location Check-In Data

With the widespread use of mobile technologies, location data based on mobile devices are becoming increasingly available. Such data contains abundant information, including some individual locations, surroundings, and the types of activities. Compared to traditional approach to obtaining information of urban activities, the use of data acquired from mobile devices enables a real-time representation of urban dynamics and their evolution over time and space (Ratti et al, 2006).

In this study, we used location check-in data provided in Sina Weibo (having a similar function as Twitter) to determine the actual urban activity. The studied temporal framework was from May 16 throughout July 28, 2013 (74 days). A total of 890 million check-in records were collected during the time period. These check-in records were linked to a total of 102,826 Point-of-interests (POIs). POIs generally have eight types based on land use classifications. They are (1) shopping, (2) entertainment, (3) hotel and public, (4) sports, (5) firm, (6) residential, (7) educational institute, and (8) restaurant. The check-in dataset was transformed into a POI-based attribute table, in which each POI record comprised a full range of information including

land-use classification, latitude and longitude, number of total check-ins, and some other geographic features.

Transit Smart Card Data

Transit smart card system was introduced in Beijing in 2003. By 2005, over 90 % of bus/subway riders in Beijing had used the transit smart card for payment. In 2006, the traditional paper passes were replaced by the smart cards in Beijing’s entire subway system. Smart card holders can have up to 80 percent discount in local bus service. The transit smart card system records a set of cardholder’s information including trips origin and destination, boarding and/or alighting time, card number, and card type (student card or regular card). The rich data recorded in the system have helped planners and researchers gain a better understanding of travel flow, and enabled transit agencies to assess and respond more precisely and timely to customer’s need.

Unlike a subway system which requires a swipe in and out, not every bus trip keeps an alighting record. That is because Beijing’s bus system uses two fare schemes – a flat fare scheme and a distance fare scheme. Under a flat fare scheme, a 0.40 CNY is charged for every single trip and it doesn’t require riders to swipe the card on the way out. As a consequence, the Smart Card Data (SCD) don’t store any information about trip’s arrival time or destination stop, only a departure time and the origin. A distance fare scheme requires cardholders to swipe twice both on boarding and alighting the bus, so the SCD contain full trip’s information.

In this study, the SCD of bus and subway system were obtained from Beijing Municipal Administration & Communications Card Co. (BMAC). These data were collected from April 5 to 11 in 2010. For bus system, though incomplete flat fare trips’ information might result in the failure of identifying travel patterns, it would be useful when a flat fare trip was taken as a transfer between two distance-fare trips. Therefore, data from both flat and distance fare schemes were used for human mobility analysis. A total of 97.9 million bus/subway trips were generated by 10.9 million cardholders during the time period. The summary of bus and subway SCD is shown in Table 1.

Table 1
A Summary of Smartcard Data

Variables	Number of Records (million)
Time	April 5-11, 2010
No. cardholders	10.9
No. Total SCD records	97.9
No. Bus records	82.7
No. Distance Fare	23.4 (28.3%)
No. Flat Fare	59.3 (71.7%)
No. Subway records	15.2

Taxi Data and Resident Travel Survey

In addition to the SCD data, we also used taxi data and Resident Travel Survey data to examine the human mobility. Taxi data was collected within one week from November 7 to 13 in 2011, with a total of 2,254,068 trip records from about 20,000 taxis. The latitude and longitude of each trip's origin and destination were stored in the system.

As the traditional major data inventory of daily travel, the Resident Transportation Survey (RTS) has assisted planners and decision makers in providing comprehensive data on resident travel behavior in Beijing. Previous surveys included the 1986, 2000, 2005 and 2010 RTS. Data was collected on daily trips taken by individual residents over a 24-hour period. Information included purpose of the trip, means of transportation, time, duration, trip's origin and destination, and individual's socio-economic attributes. All of these individual travel data were aggregated at the traffic analysis zone (TAZ) level.

In the present analysis, we used the most recent RTSs in 2005 and 2010. We only looked at the journeys to work. The 2005 RTS dataset included 70,091 home-work records from 1,118 TAZs, and the 2010 RTS included 56,619 home-work records from 1,911 TAZs.

Methodology and Results

One common method to evaluate the effectiveness of UGBs on urban expansion is to compare human activities outside and inside the boundaries (Nelson & Moore, 1993; Han *et al*, 2009). Behind the methodology lie three basic presumptions. If a city's UGBs were effective in confining undesirable human activities outside the boundaries and adhered to the statements set forth by the 2004 master plan, one would expect that:

- (1) Only a small amount of urban activities occur outside the boundaries compared to the amount within the UGBs;
- (2) There is strong positive correlation between the actual amount of urban activities and the planned population across UGBs; and
- (3) People's movement, particularly commuting travel flows, would be less likely to start or end at places outside the boundaries.

According to these presumptions, we developed three measures used for UGBs assessment. They quantified the effectiveness of UGBs with respect to urban activities, the correlation between urban activities and planned population, and human mobility, respectively. In addition, we also developed a fourth measure to measure the strength of connections between UGBs based on travel flows.

Methodology for each measure and corresponding results were elaborated in this chapter. The structure of the overall assessment process was presented in Figure 2 below.

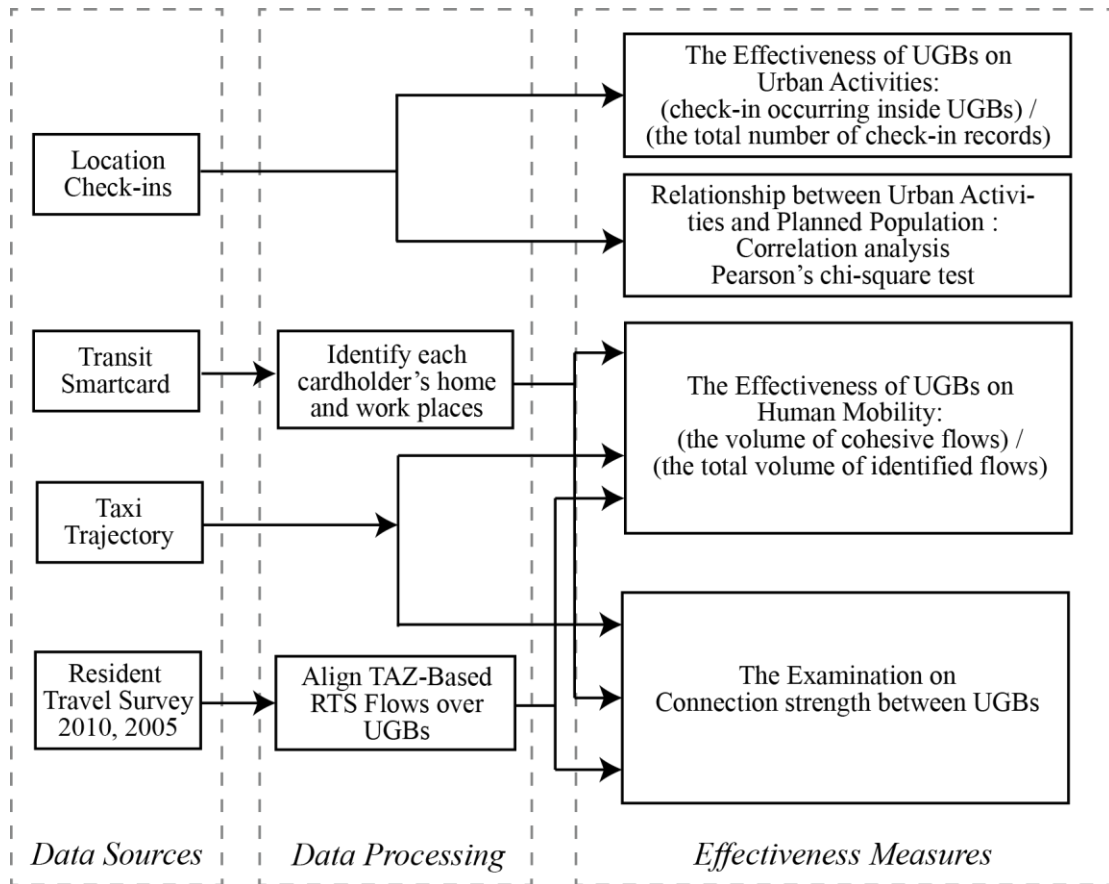

Fig.2. The Assessment Process

The Effectiveness of UGBs on Urban Activities

The effectiveness of UGBs in terms of urban activities was measured using location check-in data. We identified the locations of the check-in data after preliminary data processing. In total, there were 7,416,012 valid check-in records. The positions of urban activities can be determined according to each check-in record and classified into two groups: inside and outside the UGBs.

Figure 3 presents the locations of selected check-in data in relation to Beijing's UGBs using ArcGIS.

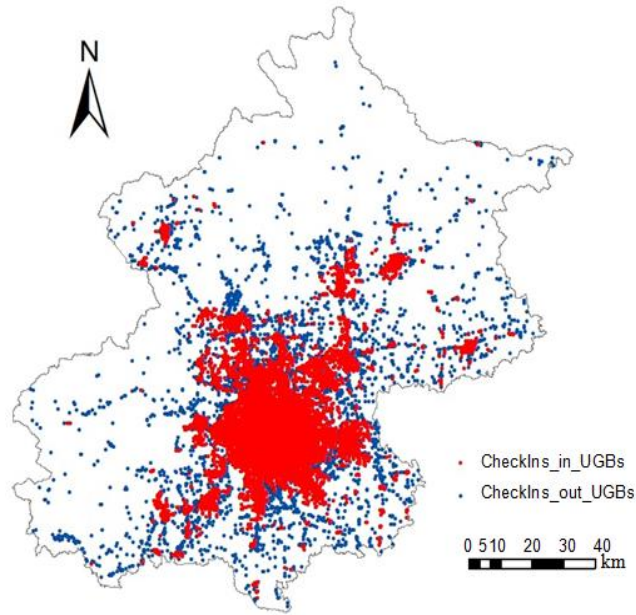

Fig. 3. Distribution of Check-ins

The effect of UGBs in terms of urban activities, therefore, was measured by the ratio of check-in number inside the UGBs to the total check-in number. This measure was defined as E_a and stated as follows:

$$E_a = CI_{in} / CI \quad (3-1)$$

Where CI_{in} refers to the number of check-in inside the UGBs, and CI refers to the total check-in number.

Of a total of 7,416,012 check-in records, the number of urban activities occurring within the UGBs was 7,187,191, accounting for 96.91%. Given an overwhelming majority of check-in records occurring within the UGBs, it is safe to conclude that Beijing's UGB have been effective in containing urban activities.

Relationship between Urban Activities and Planned Population

This section discussed the relationship between urban activities and population. To do so, we calculated the correlation coefficient to examine the linear relationships between the number of check-ins and planned population. This calculation was made by two steps: first, the whole city was examined to indicate the overall situations; and second, areas excluding the central city were examined to show the situations of the newly developed areas. We also used Pearson's chi-square test to check how likely the observed differences between the check-in numbers across the UGBs reflected the relationships between planned population across the central city and new cities.

The results were presented in Table 2 and 3. When the central city was included, the correlation coefficient between check-ins and population was 0.655, significant at the 0.05 level. While when the central city was excluded, the correlation coefficient was 0.881, significant at the 0.01 level.

Table 2
Correlation Analysis of Check-ins and Planned Population with the Central City Included

		Planned Population
Check-ins	Pearson Correlation	.655*
	Sig. (2-tailed)	.021
	N	12

*: Correlation is significant at the 0.05 level

Table 3
Correlation Analysis of Check-ins and Planned Population with the Central City Excluded

		Planned Population
Check-ins	Pearson Correlation	.881**
	Sig. (2-tailed)	.000
	N	11

** : Correlation is significant at the 0.01 level

In addition to the correlation analysis, we also examined whether or not the actual distribution of urban activities, presented by check-in data, fitted the distribution of planned population across the UGBs. We used Pearson’s chi-square test for the central city and new cities. New towns were excluded from our analysis because the population of towns had not been specified in the 2004 master plan. The null hypothesis in this case was that the proportions between each group’s check-in were consistent with the proportions between each group’s planned population. The value of the test-statistics is:

$$\chi^2 = \sum_{i=1}^n \frac{(O_i - E_i)^2}{E_i} \quad (3-2)$$

Where χ^2 is Pearson’s test statistics, O_i stands for the observed check-ins frequency, and E_i stands for the expected check-ins frequency.

Table 4 listed the number of check-in records, planned population, areas, and densities for central city and new cities. In addition to the overall chi-square value, we also calculated a test statistic that excluded the central city check-ins (92.71% of total records). By doing so, we can preclude the potential influences of the overwhelming check-ins concentrated in the central city and can better understand the relationship among new cities. The chi-squared test of check-ins including and excluding central city were presented in Table 5 and 6, respectively.

Table 4

Check-ins and Planned Population of the Central City and New Cities in Beijing

UGB	Check-ins	Planned Pop. in 2020	Area(km ²)	Density of Check-ins	Density of Planned Pop.
Central City	7,251,872	8,500,000	1,196.4	6,061.6	7,104.8
Huairou	50,960	350,000	41.0	1,243.8	8,542.6
Shunyi	84,831	900,000	130.2	651.4	6,911.0
Mentougou	8,937	250,000	36.4	245.8	6,876.0
Miyun	32,729	350,000	56.0	584.9	6,255.2
Fangshan	46,381	600,000	65.6	707.3	9,149.7
Yanqing	11,001	150,000	18.5	596.2	8,129.5
Tongzhou	113,512	900,000	89.9	1,262.9	10,013.2
Pinggu	8,069	257,000	27.9	289.8	9,229.1
Changping	75,057	600,000	73.42	1,022.3	8,171.8
Daxing	89,178	600,000	71.93	1,239.8	8,341.2
Yizhuang	49,265	700,000	101.4	485.7	6,901.8

Table 5

Chi-Square Test of Check-ins with the Central City Included

UGB	Actual Check-ins (a)	Excepted Check-ins (b)	(a-b) ² /b
Central City	7,251,872	4,696,279.7	1,390,686.3
Huairou	50,960	193,376.2	104,885.6
Shunyi	84,831	497,253.2	342,063.3
Mentougou	8,937	138,125.9	120,830.1
Miyun	32,729	193,376.2	133,457.6
Fangshan	46,381	331,502.1	245,229.3
Yanqing	11,001	82,875.5	62,333.8
Tongzhou	113,512	497,253.2	296,141.5
Pinggu	8,069	141,993.4	126,313.9
Changping	75,057	331,502.1	198,382.1
Daxing	89,178	331,502.1	177,136.0
Yizhuang	49,265	386,752.5	294,497.9
Sum	7,821,792	7,821,792	3,491,957.5

Table 6

Chi-Square Test of Check-ins with the Central City Excluded

UGB	Actual Check-ins (a)	Excepted Check-ins (b)	(a-b) ² /b
Huairou	50,960	34,995.1	7,283.3
Shunyi	84,831	89,987.4	295.5
Mentougou	8,937	24,996.5	10,317.7
Miyun	32,729	34,995.1	146.7
Fangshan	46,381	59,991.6	3,087.9
Yanqing	11,001	14,997.9	1,065.2
Tongzhou	113,512	89,987.4	6,149.8

Pinggu	8,069	25,696.4	12,092.2
Changpin	75,057	59,991.6	3,783.3
Daxing	89,178	59,991.6	14,199.4
Yizhuang	49,265	69,990.2	6,137.0
Sum	569,920	569,920	64,558.1

The chi-square value for the central-city-included case was 3,491,957.5, with a p-value was 0.000, proving a significance at 0.01 level. When the central city’s data were excluded from the dataset, the chi-square value was 64,558.1 with a p-value of 0.000, also proving a significance at 0.01 level. Therefore, the null hypothesis was rejected and we could conclude that the distribution of urban activities, represented by check-ins, didn’t correlate with the distribution of population.

The Effectiveness of UGBs in Containing Human Mobility

When UGBs are effectively implemented, one would expect that most of urban land uses and facilities are built inside the UGBs, and the majority of travel flows, particularly commuting travel flows, should start and end inside the UGBs. Therefore, the effectiveness of UGBs in terms of human mobility can be measured by the number of travel flows occurring within UGBs relative to the total number of travel flows.

Prior to the examination of travel flow patterns, it is crucial to determine the locations of flow’s origin and destination. According to the origins and destinations relative to the UGBs, flows can be classified into “cohesive flows” and “disperse flows”. A cohesive flow refers to a trip where both the origin and destination are located within the UGBs. A disperse flow refers to a trip where at least one end of the trip is outside any given UGBs. An illustration of cohesive and disperse flows is presented in Figure 4.

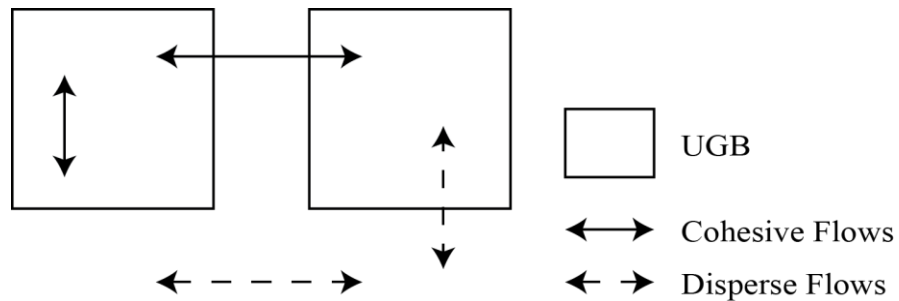

Fig.4. An Illustration of Cohesive and Disperse Flows

Similar to the approach to the evaluation of urban activities, this effectiveness measure, defined as E_f , was calculated as follows:

$$E_f = F_l / F \quad (3-3)$$

Where F_l refers to the volume of cohesive flows, and F refers to the total volume of identified flows.

An Examination of Smart Card Data

The raw SCD collected from bus and subway system needed to be pre-processed to extract valid journeys to work travel flows. A proper study of the journey to work is important because it can provide us with insights into the city's structure and the relations between various types of urban elements. The analysis, therefore, focused solely on the journey to work and didn't look at leisure travel or other non-work-related trips, including schooling trips.

In terms of the bus/subway system, we used the one-day data to locate a cardholder's home and work places and repeated this process for every single weekday. Based on the repetitive pattern of the journey to work in the given week, these one-day data of individual cardholders were compiled and refined to determine the final home and work locations. Data from the subway system were processed in the same way. This methodology has been elaborated by Long and Thill (2014). The overall identification process can be briefly summarized as follows.

If a place meets the following conditions, it is regarded as a cardholder's work location:

- 1) The card type is not student card;
- 2) $D_w \geq 6$ hours, where D_w is the duration that a cardholder stays at place w , which is within 500 meters of any given bus stops/subway stations;
- 3) $w \neq 1$, which means that w is not the first place that the system records in a day;
- 4) The place where a cardholder visited most frequently in five weekdays would be defined as the final job place.

Similarly, a place is regarded as a cardholder's home if it meets the following conditions:

- 1) The card type is not student card;
- 2) The cardholder has an identified workplace;
- 3) The place where a cardholder get on a bus/subway most frequently in the morning of five weekdays would be defined as the final home place.

As a result, a total of 703,293 cardholders (approximately 6.5% of all 10.9 million cardholders) have been identified to have both the work and home locations. Based on these records, E_f —the overall effectiveness measure— was calculated. Of 703,293 commuting flows, 664,968 have both the origins the destinations located within the UGBs, accounting for 94.6% of the total.

An Examination of Taxi Data

Unlike the SCD which require additional process to obtain valid travel flow information, taxi trajectory data contain detailed and accurate travel logs that can be directly used to geocode origins and destinations of trips. Based on the cohesive/disperse flow criteria listed

above, 2,185,777 of taxi records were identified as cohesive flows, accounting for 97 percent of total flows (2,253,437).

An Examination of Resident Travel Survey

For RTS, commuting related data were accumulated at the traffic analysis zone (TAZ) level. But in reality, the boundaries of TAZs do not fit well with the UGBs. An illustration of this situation was presented in Figure 5, as two UGBs were cut into four pieces (they are A, B, C and D) by four TAZs (1, 2, 3 and 4).

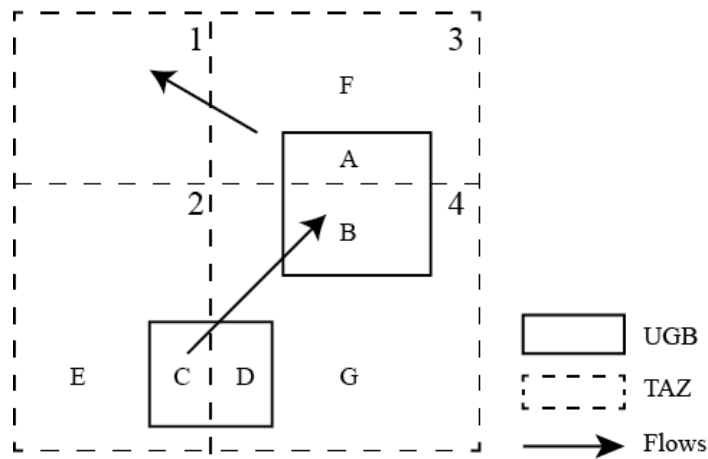

Fig. 5. An Illustration of RTS Flows over UGBs and TAZs

Consequently, we proposed a flow-dividing methodology to assign home and work places from RTS to UGBs. We assumed that flows’ origins and destinations were spatially homogeneously distributed in each TAZ. Therefore, the probability of a flow’s origin or destination falling into a given UGB was proportionate to the share of overlapping area between UGB and TAZ relative to the entire TAZ. Correspondingly, the probability of this journey to work occurring in certain direction can be calculated by multiplying these two probabilities. In case of Figure 6 illustrated, assume that parcel C and E made up 10 and 90 percent of TAZ 2 total area, respectively. Parcel B, D, and G accounted for 20, 10, and 70 percent of TAZ 4 total area. The probability of flows in each direction then was calculated, as presented in Table 7.

Table 2
An Illustration of Flow-Dividing Method for Assigning TAZ Flows over UGBs

Origin (TAZ 2)	Proportion (area)	Destination (TAZ 4)	Proportion (area)	Probability (flow)	Type
C (Inside UGB)	10 %	B (Inside UGB)	20 %	0.02	Inter-UGBs
		D (Inside UGB)	10 %	0.01	Intra-UGBs
		G (Outside UGB)	70 %	0.07	One-end-inside- UGBs

E (Outside UGB)	90 %	B (Inside UGB)	20 %	0.18	One-end-inside- UGBs
		D (Inside UGB)	10 %	0.09	One-end-inside- UGBs
		G (Outside UGB)	70 %	0.63	Outside-UGBs

Furthermore, we classified flows into four types based on the locations of their origins and destinations relative to the extent of UGBs. They were inter-UGBs, intra-UGBs, one-end-inside- UGBs, and entirely-outside-UGBs flows. Given the definition mentioned earlier, inter- and intra- UGBs flows belong to the cohesive flow group. Examining data from RTS in 2010 and 2005, we found that 86.5 percent and 91.1 percent of journeys to work happened within the UGBs.

A summary of cohesive and disperse flows from these four data sources were presented in Table 8.

Table 3
Cohesive and Disperse Flows by Four Data Sources

Date Sources	No. Cohesive Flows	No. Total Valid Flows	Cohesive Percentage
Smartcard Data	664,968	703,293	94.6%
Taxi Data	2,185,777	2,253,437	97.0%
TAZ Data (2010 RTS)	48,794.8	56,435	86.5%
TAZ Data (2005 RTS)	63,618.3	69,858	91.1%

Flows between UGBs

A strong connection between two places usually incurs large amount of travel flows. By counting commuting and other trips, we can measure the strength of connection between the UGBs, and have a better understanding of the area's overall connection structure.

For SCD and RTS data, the work and home places of each trip have already been identified through the process mentioned above. These trips' origins and destinations were then aggregated at the UGB level. Origins and destinations extracted from taxi trajectories data were also geocoded and aligned with UGBs.

The final results by four types of data input were presented in Table 9. UGBs were grouped into two types by central city and new cities.

Table 4
Flows Structure by Four Data Sources

Flows	SCD	Taxi	RTS (2010)	RTS (2005)
Inside CC*	31,475,282 (73.6%)	2,120,745 (94.1%)	39,934.9 (70.8%)	58,814.5 (84.2%)
Inside NC*	1,259,984 (2.9%)	13,827 (0.6%)	2,635.8 (4.7%)	569.9 (0.8%)

Between NCs	51,388 (0.1%)	346 (0.0%)	249.4 (0.4%)	117.8 (0.2%)
Between CC and NCs	2,813,781 (6.6%)	21,635 (1.0%)	5,055.9 (9.0%)	4,041.1 (5.8%)
Between CC and OU*	2,607,835 (6.1%)	63,985 (2.8%)	4158.8 (7.4%)	4,785.0 (6.9%)
Between NC and OU	2,825,294 (6.6%)	6,587 (0.3%)	3150.5 (5.6%)	933.4 (1.3%)
Two ends OU	1,878,338 (4.4%)	26,312 (1.2%)	1249.6 (2.2%)	566.0 (0.8%)
Beyond Beijing**	0	631 (0.0%)	0	0

* "CC" stands for "central city", "NC" for "new cities", and "OU" for "outside UGBs";

** It refers to a flow with origin or destination located outside Beijing.

Figure 6 visualized the connection between central city and new cities. We also ranked these 11 new cities based on connection strength and listed them in Table 10. Tongzhou, Daxing, and Yizhuang have the strongest connection with central city; while cities in the north, including Miyun, Pinggu, Huairou, and Yanqing, have relatively weaker connection with central city.

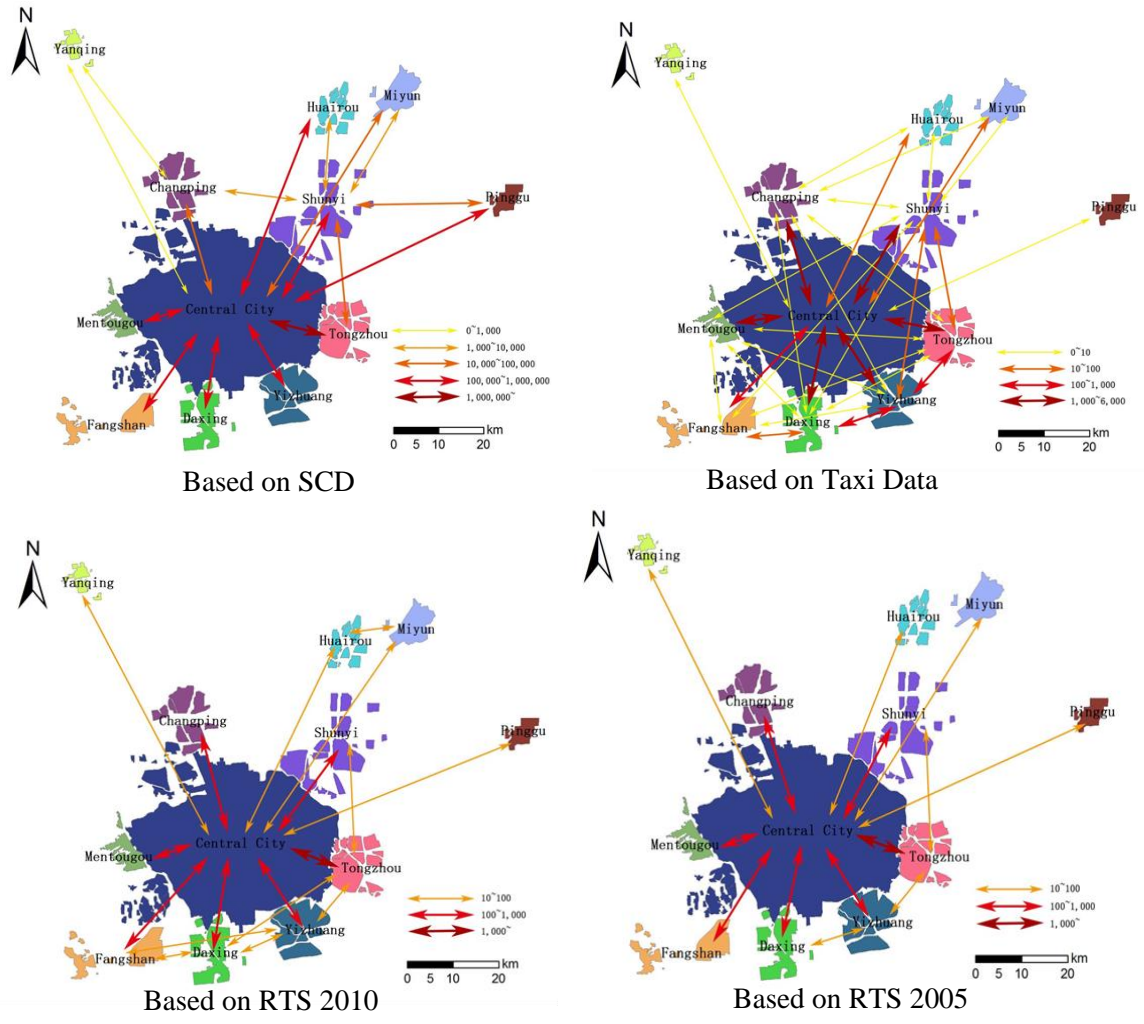

Fig. 6. Connections between UGBs by Four Data Sources

Table 5
Connection Strength Between the Central City and New Cities

New Cities	Rank (SCD)	Rank (Taxi)	Rank (RTS, 2010)	Rank (RTS, 2005)	Rank* (Arithmetic Mean)	Strength
Tongzhou	1	3	1	1	1	Strong
Daxing	6	2	2	2	2	Strong
Yizhuang	2	1	4	3	3	Strong
Mentougou	4	5	3	7	4	Medium
Shunyi	5	4	7	4	5	Medium
Fangshan	3	7	5	6	6	Medium
Changping	10	6	6	5	7	Medium
Miyun	9	9	9	8	8	Weak
Pinggu	7	11	8	9	9	Weak
Huairou	8	8	10	10	10	Weak
Yanqing	11	10	11	11	11	Weak

New Cities	Rank (SCD)	Rank (Taxi)	Rank (RTS, 2010)	Rank (RTS, 2005)	Rank* (Arithmetic Mean)	Strength
------------	---------------	----------------	---------------------	---------------------	----------------------------	----------

* Rankings were derived from the sum of flows by four data sources divided by 4

Discussion

The results of the present analysis suggested that Beijing's UGBs were effective in containing human activities. In terms of the urban activities, over 96 % of check-ins occurred inside the UGBs. For the human mobility, 94.6 % of all commuting travel flows identified through transit smartcard data and 97 % of all taxi trajectories are belong to "cohesive flow", where both the origin and destination are located within the UGBs. Based on the traditional Residential Travel Survey (RTS) data, "cohesive flow" accounts for 86.5 % and 91.1 % of the overall "journey to work" flows in 2010 and 2005, respectively.

As had expected, we found there is a relative strong positive correlation between the planned population and the amount of urban activities, presented by check-in data. This was particularly the case when we excluded the central city's data and only considered the 11 new cities. However, the actual distribution of check-in data didn't fit with the distribution of planned population across the UGBs. This showed that the relationship between urban activities and population is very unlikely to be linear. A larger population is usually associated with more diverse, more complex, and more unpredictable human activities. Consequently it would be reasonable to observe a disparity between expected and actual amount of activities. One merit of this approach, however, is to provide a quick and explicit way to monitor the urban activities pattern over time and space and to identify potential imbalance of development. For example, Fangshan, Changping, and Daxing each have a planned population of 600,000, but their numbers of check-ins are significantly different (presented by 46,381, 75,057, and 89,178, respectively). This observation serves as a starting point for planners to make further analysis of urban development issues, such as the separation of workplace and residence and the vitality of a new city. More hidden reasons would be explored based on the analysis of human activities.

The examination of the flows between UGBs indicated that Beijing's plan had generally accomplished the basic strategy to decentralize population. The results of inter-UGBs connections analysis also suggested the limited achievements of the 2004 Master Plan in new cities development. The comparison between RTS data in 2010 and in 2005 showed that there had been a decrease in the number of "journey to work" occurring inside the central city, slight increase in the number of trips occurring inside new cities and between the central city and new cities. It indicated that new cities have been effective in extracting population from the central city. According to the plan, Tongzhou, Shunyi, and Yizhuang were listed as the top three pilot development districts. The transportation infrastructures (e.g. new subway lines) in these

three cities should be built in priority in order to provide stronger connections with the central cities. However, the analysis results revealed that, with only a medium strength ranking, Shunyi failed to accomplish its goal. The disparity between the smartcard and the overall flow rankings also implied a need for more investment in public transit. For example, Daxing ranked 2nd in terms of the overall flow connections, but its SCD ranking was only 6th. It implied that though there had been a strong commuting connection between Daxing and the Central city, people may primarily rely on automobiles or taxis instead of transit. In addition to that, the shares of SCD flows “between CC and NCs”, “between CC and OU”, and “between NCs and OU” are almost the same, although those between CC and NCs had been expected to be much more than the other types. This indicated that the public transit between new cities and the central city was relatively weak and needs improvement in future.

Conclusions

Evaluating plan implementation is important because it tells whether or not a plan successfully accomplishes its intents and objectives. This is particularly relevant in the case of UGB’s implementation. Different from most previous studies which focused on land uses, the present research focused on the human activities and travel flows in relation to the containment effects of UGBs. Using this approach, we can gain much meaningful perspectives of how UGBs are acting on human activities.

The research applied the location check-in data, transit smart card data, taxi data and resident travel survey data to evaluate the effectiveness of urban growth boundaries in Beijing. The human activities and travel flows across UGBs and different types of urban regions are examined in detail.

The large proportions of intra-and inter-boundary travel flows, along with an overwhelming majority of check-ins occurring inside the UGBs indicated that Beijing’s UGBs were successful in containing human activities. This was quite different from previous studies based on land use examinations, such as Han *et al.* (2009)’s results. Moreover, the spatial differentiation of the travel flows clearly indicated the underdevelopment of the public transit systems of several pivot new cities, calling for necessary consolidation and adjustment of current planning strategies.

Future research may explore the rules of human activities and travel flows based on data of a longer time horizon, such as considering impacts of different seasons or weather on human activities and travel modes. In addition, based on the data of human activities and travel flows, future research may also be able to explore in detail the relations between land uses, facilities construction and human activities.

References

- Alexandar, E. R., & Faludi, A. (1989). Planning and Plan Implementation: Notes on Evaluation Criteria. *Environment and Planning B: Planning and Design*, 16, 127-140.
- Alexander, E. R. (2009). Dilemmas in Evaluating Planning, or back to basics: What is Planning for? *Planning Theory and Practice*, 10(2), 233-244.
- Alterman, R., & Hill, M. (1978). Implementation of Urban Land Use Plans. *Journal of the American Institute of Planners*, 33(1), 274-285.
- Altes, W. K. (2006). Stagnation in Housing Production: Another Success in the Dutch Planner's Paradise? *Environment and Planning B: Planning & Design*, 33, 97-114.
- Berke, P., Backhurst, M., Day, M., Ericksen, N., Laurian, L., Crawford, J., et al. (2006). What Makes Plan Implementation Successful? An Evaluation of Local Plans and Implementation Practices in New Zealand. *Environment and Planning B: Planning and Design*, 33, 581-600.
- Boarnet, M. G., McLaughlin, R. B., & Carruthers, J. I. (2011). Does State Growth Management Change the Pattern of Urban Growth? Evidence from Florida. *Regional Science and Urban Economics*, 41(3), 236-252.
- Brody, S. D., Carrasco, V., & Highfield, W. E. (2006). Measuring the Adoption of Local Sprawl: Reduction Planning Policies in Florida. *Journal of Planning Education and Research*, 25, 294-310.
- Brody, S. D., Highfield, W. E., & Thornton, S. (2006). Planning at the Urban Fringe: An Examination of the Factors Influencing Nonconforming Development Patterns in Southern Florida. *Environment and Planning B: Planning and Design*, 33, 75-96.
- Brueckner, J. K., & Fansler, D. A. (1983). The Economics of Urban Sprawl: Theory and Evidence on the Spatial Sizes of Cities. *The Review of Economics and Statistics*, 65, 479-482.
- Burchfield, M., Overman, H. G., Puga, D., & Turner, M. A. (2006). Causes of Sprawl: A Portrait from Space. *Quarterly Journal of Economics*, 121, 587-633.
- Chapin, T. S., Deyle, R. E., & Baker, E. J. (2008). A Parcel-based GIS Method for Evaluating Conformance of Local Land-Use Planning with a State Mandate to Reduce Exposure to Hurricane Flooding. *Environment and Planning B: Planning and Design*, 35, 261-279.

- Ding , C., Song, Y., & Knaap, G. (2005). *Growth Scenario for Beijing 2020: Technical Report on the Beijing's 2020 Comprehensive Plan Revision Process*. Cambridge, MA: Lincoln Institute of Land Policy.
- Han, H., Lai, S.-K., Dang, A., Tan, Z.-b., & Wu, C.-f. (2009). Effectiveness of Urban Construction Boundaries in Beijing: An Assessment. *Journal of Zhejiang University Science A*, 10(9), 1285-1295.
- Hasse, J. (2007). Using Remote Sensing and GIS Integration to Identify Spatial Characteristics of Sprawl at the Building-Unit Level. In V. Mesev, *Integration of GIS and Remote Sensing* (pp. 117-148). Hoboken, NJ: Wiley.
- Hepinstall-Cymerman, J., Coe, S., & Hutyra, L. R. (2013). Urban Growth Patterns and Growth Management Boundaries in the Central Puget Sound, Washington, 1986-2007. *Urban Ecosyst*, 16, 109-129.
- Laurian, L., Day , M., Berke, P., Ericksen, N., Backhurst, M., Crawford, J., et al. (2004). Evaluating Plan Implementation: A Conformance-Based Methodology. *Journal of the American Planning Association*, 70(4), 471-480.
- Long, Y., Gu, Y., & Han, H. (2012). Spatiotemporal Heterogeneity of Urban Planning Implementation Effectiveness: Evidence from Five Urban Master Plans of Beijing. *Landscape and Urban Planning*, 103-111.
- Long, Y., & Thill, J.-C. (2014). Combining smart card data, household travel survey and land use pattern for identifying housing-jobs relationships in Beijing. *Computers, Environment and Urban Systems*, Under Review
- Nelson, A. C., & Moore, T. (1993). Assessing Urban Growth Management: The case of Portland, Oregon, the USA's Largest Urban Growth Boundary. *Land Use Policy*, 293-302.
- Oliveira, V., & Pinho, P. (2010). Evaluation in Urban Planning: Advances and Prospects. *Journal of Planning Literature*, 24(4), 343-361.
- Pendall, R., Martin, J., & Fulton, W. (2002). *Holding the Line: Urban Containment in the United States*. Washington, DC: Brookings Institution.
- Talen, E. (1996). After the Plans: Methods to Evaluate the Implementation Success of Plans. *Journal of Planning Education and Research*, 16, 79-91.
- Talen, E. (1996). Do Plans Get Implemented? A Review of Evaluation in Planning. *Journal of Planning Literature*, 10, 248-259.